



GLOBAL

PRODUCTS SUPPLY COMPANY

Paramount Quality since 1999

CAST IRON DOUBLE TRIANGULAR COVER & GRATING WITH SQUARE FRAME

Heavy Duty As per BS 497/1976
 Test Load : 350KN - Block dia. 300mm.

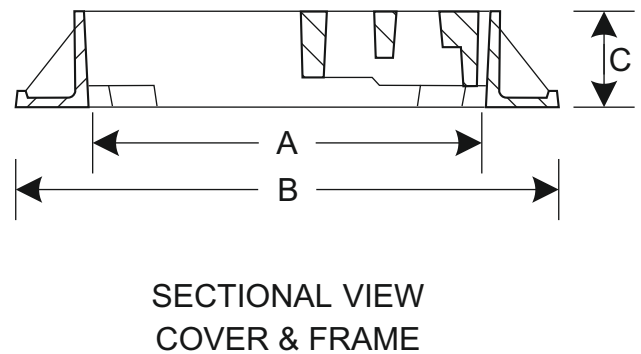
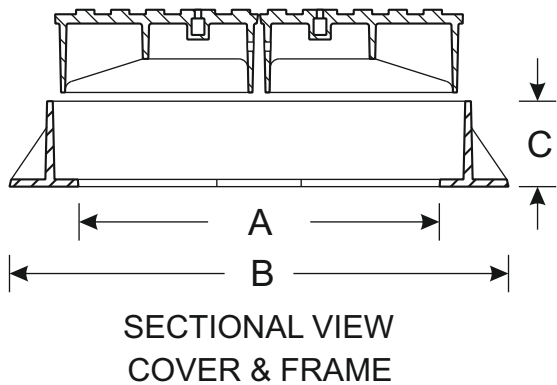
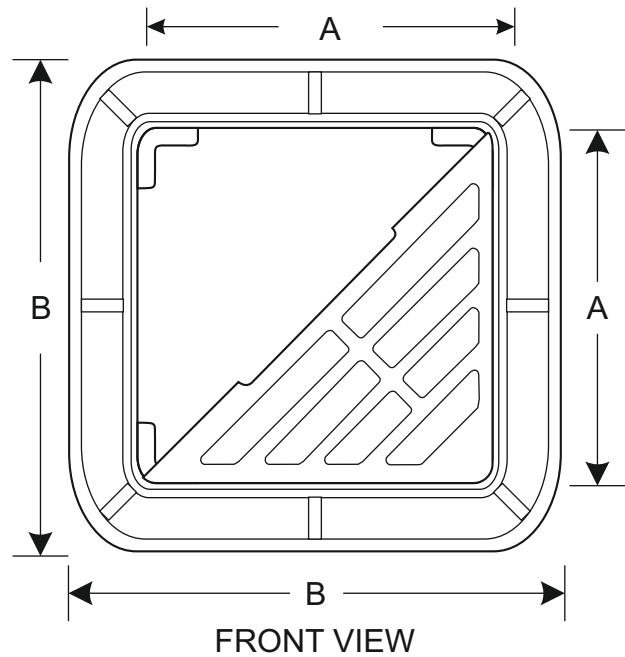
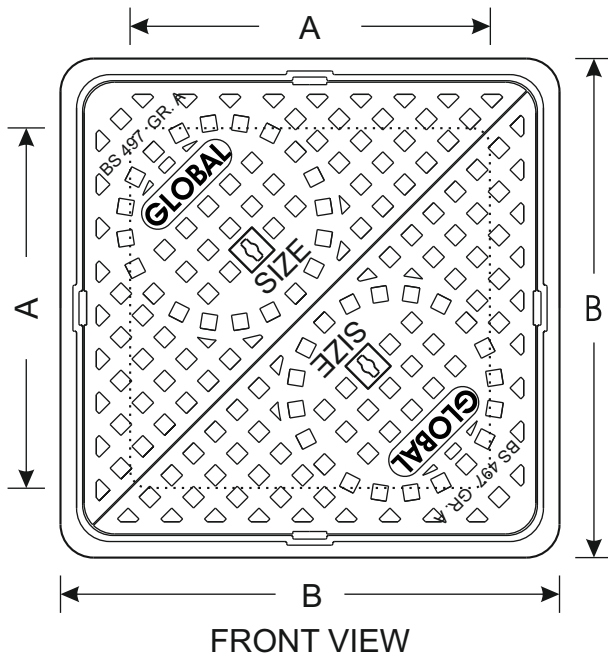

Sr. No.	B.S. Ref.	Clear opening of Frame (mm.) A x A	Over base of Frame (mm.) B x B	Height (mm.) C	Weight each (Kgs.)	Solid top COVER & FRAME
035	MB1 60	600 X 600	750 X 750	100	145 Kgs	Double Triangular Covers with Square Frame H/D Gr. A
036	MA 60	600 X 600	750 X 750	100	180 Kgs	Double Triangular Covers with Square Frame H/D Gr. A
037	MA 60	600 X 600	750 X 750	150	200 Kgs	Double Triangular Covers with Square Frame H/D Gr. A
038	GA1 450	450 X 450	600 X 600	100	90 Kgs	Double Triangular Gully Gratings & Frame H/D Gr. A
039	GA1 450	475 X 475	625 X 550	100	95 Kgs	Double Triangular Gully Gratings & Frame H/D Gr. A
040	-	600 X 600	750 X 750	100	180 Kgs	Double Triangular Gully Gratings & Frame H/D Gr. A